

SENSORE EFFETTO HALL PER LA MISURA DI GIRI/VELOCITA' IN RUOTE FONICHE O DENTATE
HALL EFFECT SENSOR FOR MEASUREMENT OF SPEED/RPM FROM PHONIC WHEEL OR GEAR WHEEL

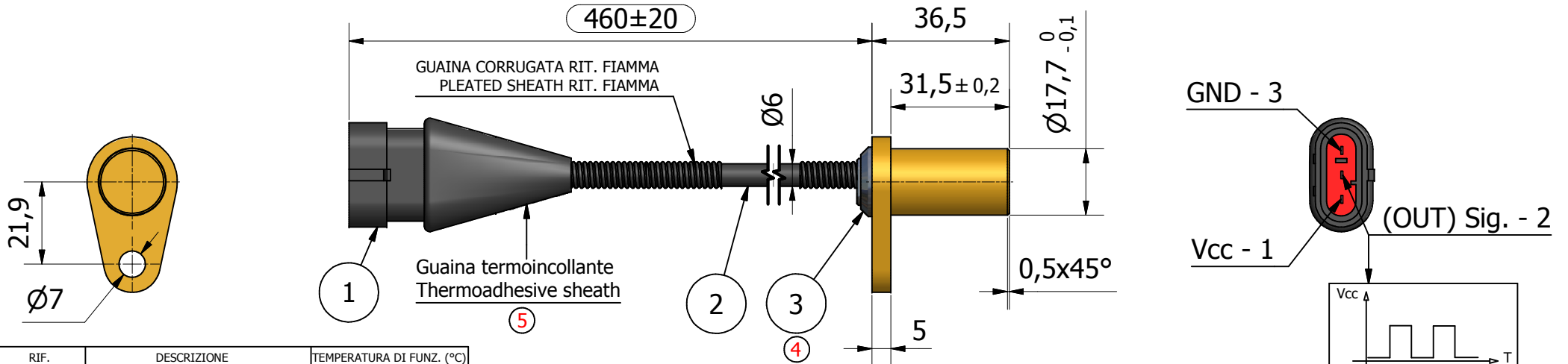

RIF.	DESCRIZIONE	TEMPERATURA DI FUNZ. (°C)
1	TYCO SUPERSEAL 1.5 series 3 Pin CONTACT	-40 / +125
2	CAVO/CABLE HT 105° - Ø6mm	-40 / +105
3	TAPPO NYLON 6.6 NYLON 6.6 CAP	-30 / +130

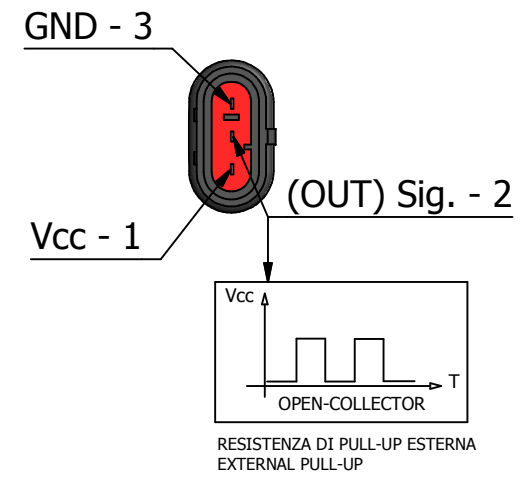
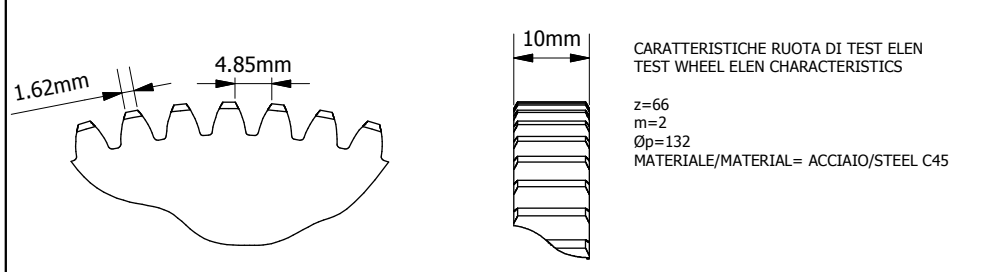
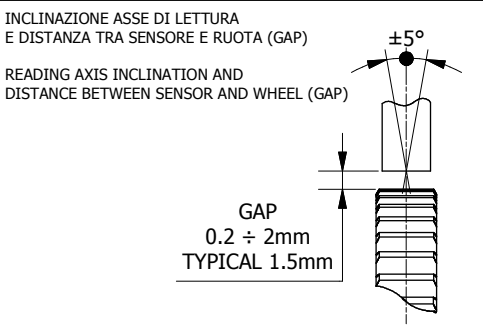
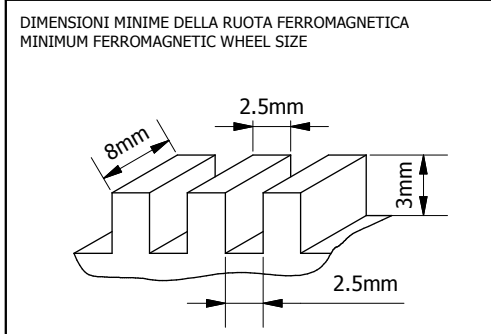

6 **APPLICAZIONI TIPICHE - SENSORE PER USO AUTOMOTIVE**
TYPICAL APPLICATIONS - AUTOMOTIVE SENSOR

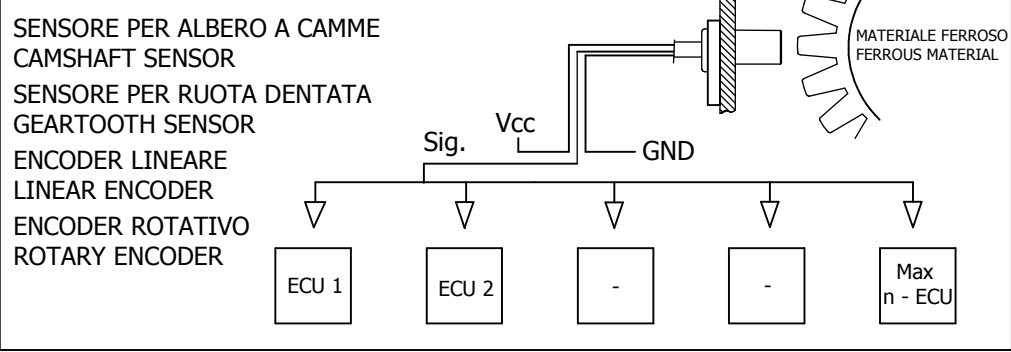

ATTENZIONE ! - Dispositivo sensibile alle cariche elettrostatiche
Il processo di pittura può danneggiare permanentemente il dispositivo
Proteggere il connettore con un coperchio di plastica isolante

CAUTION! - Electrostatic discharge sensitive device.
The painting process can permanently damage the device.
Protect the connector with an insulating plastic cover

REV.	DATA	FIRMA	DESCR. ULT. REV.
4	09/06/08	Fabio S.	Aggiornate caratteristiche ruota di lettura
5	18/11/08	Pasetti F.	
6	11/09/09	Fabio S.	
7	11/10/11	Fabio S.	

	ELEN srl Viale Forlanini 71 Garbagnate Milanese (MI)	
	DATA: 12/07/2007	DENOMINAZIONE: SENSORE GIRI EFF. HALL L=31.5mm TYCO
	SCALA: 1:1.5	CODICE PRODOTTO: AA.02.0020-1
	DIS.: Fabio S.	1/3
UNITA DI MISURA: mm	Quote senza indicazione di tolleranza : ISO 2768 - m	

CARATTERISTICHE:

SENSORE ZERO SPEED

ALIMENTAZIONE: Min 4.5 Vcc Max 30 Vcc

CORRENTE IN USCITA: Max 350 mA

FREQUENZA: 15 kHz

PROTEZIONE DA INVERSIONE DI POLARITA'

USCITA SEGNALE (FREQ.): OPEN COLLECTOR

GRADO DI PROTEZIONE: IP67

STRESS DA VIBRAZIONE: 1mm/80Hz (~4g)

TEMPERATURA DI UTILIZZO: -40°C ÷ +150°C

FORZA DI SERRAGGIO: 25 Nm

MATERIALE CORPO: OT58 TORNITO

6

TEMPERATURA DI FUNZIONAMENTO:	-40°C ÷ +150°C VALORE RIFERITO AL CASE INSERITO A RIDOSSO DELLA RUOTA	EN 60068-2-1;EN 60068-2-2 EN 60068-2-30;EN 60068-2-14
TEMPERATURA DI STOCCAGGIO:	-50°÷ +150°C	EN 60068-2-1;EN 60068-2-2 EN 60068-2-30;EN 60068-2-14
RESISTENZA A VIBRAZIONI:	1mm / 80Hz (~4g)	EN 60068-2-6
GRADO DI PROTEZIONE:	IP 67	IEC 60529
COMPATIBILITA' EMC:	BCI - CLASS "A" - 100mA ; 1÷400 MHz	ISO 11452-4 (2005)
PROTEZIONE DA INVERSIONE DI POLARITA':	-30Vcc PER 1h	PROCEDURA ELEN
PROTEZIONE DA SOVRACCARICO:	420mA PER 5'	PROCEDURA ELEN
PROTEZIONE DA SOVRATENSIONE:	36V PER 5'	PROCEDURA ELEN
PROTEZIONE DA CORTOCIRCUITO:	VERSO MASSA PER 5' VERSO Vcc PER 5'	PROCEDURA ELEN
TENSIONE DI ALIMENTAZIONE:	Min. 4,5 Vcc Max. 30 Vcc	PROCEDURA ELEN
USCITE PROTETTE PER SCARICHE ELETTROSTATICHE FINO A 2000 V SECONDO MODELLO HBM		RIF. : MIL-STD-883; method 3015.

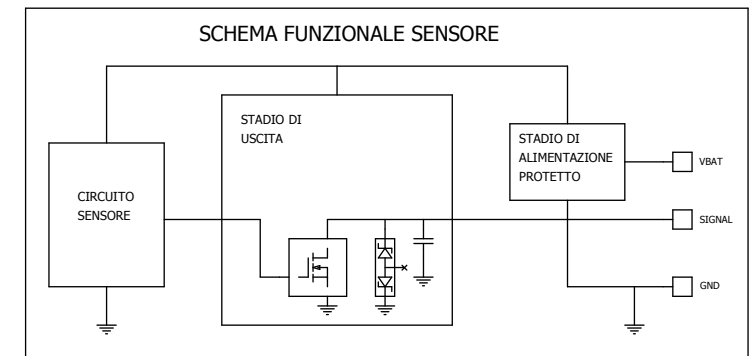
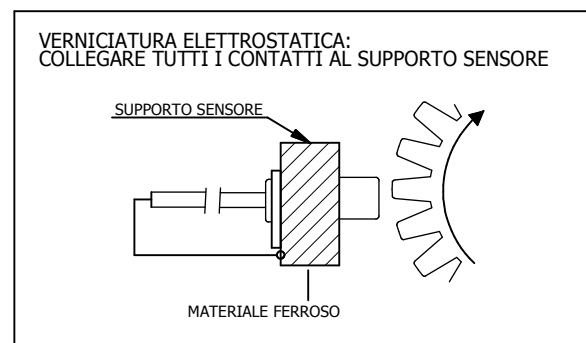
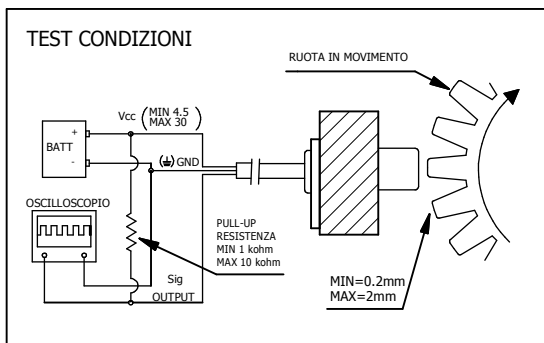

NOTE: LA ELEN SI RISERVA DI INSERIRE MIGLIORAMENTI/VARIAZIONI DI PRODOTTO, DANDONE COMUNQUE COMUNICAZIONE AL CLIENTE.
LA ELEN NON SI ASSUME ALCUNA RESPONSABILITA' SULL'USO NON APPROPRIATO DEL PRODOTTO O PER APPLICAZIONI FUORI SPECIFICA.

CHARACTERISTICS:

ZERO SPEED SENSOR

POWER SUPPLY: Min 4.5 Vdc Max 30 Vdc

OUTPUT CURRENT: Max 350mA

FREQUENCY: 15 kHz

PROTECTED BY POLARITY INVERSION

OUTPUT SIGNAL (FREQ.): OPEN COLLECTOR

DEGREE OF PROTECTION: IP67

STRESSES: 1mm/80Hz (~4g)

OPERATING TEMPERATURE: -40°C ÷ +150°C

TIGHTENING TORQUE: 25 Nm

BODY MATERIALS: OT58 LATHED

6

OPERATING TEMPERATURE:	-40°C ÷ +150°C VALUE REFERRED TO A CASE MOUNTED BEHIND THE WHEEL	EN 60068-2-1;EN 60068-2-2 EN 60068-2-30;EN 60068-2-14
STORAGE TEMPERATURE:	-50°÷ +150°C	EN 60068-2-1;EN 60068-2-2 EN 60068-2-30;EN 60068-2-14
VIBRATIONS RESISTANCE:	1mm / 80Hz (~4g)	EN 60068-2-6
DEGREE OF PROTECTION:	IP 67	IEC 60529
EMC COMPATIBILITY:	BCI - CLASS "A" - 100mA ; 1÷400 MHz	ISO 11452-4 (2005)
REVERSE POLARITY PROTECTION:	-30Vdc FOR 1h	ELEN PROCEDURE
OVERLOAD PROTECTION:	420mA FOR 5'	ELEN PROCEDURE
OVERVOLTAGE PROTECTION:	36V FOR 5'	ELEN PROCEDURE
SHORTCIRCUIT PROTECTION:	TO GROUND FOR 5' TO Vdc FOR 5'	ELEN PROCEDURE
POWER SUPPLY:	Min. 4,5 Vdc Max. 30 Vdc	ELEN PROCEDURE
OUTPUT PINS ARE PROTECTED AGAINST 2000V ELECTROSTATIC DISCHARGE ACCORDING TO HBM		RIF. : MIL-STD-883; method 3015.

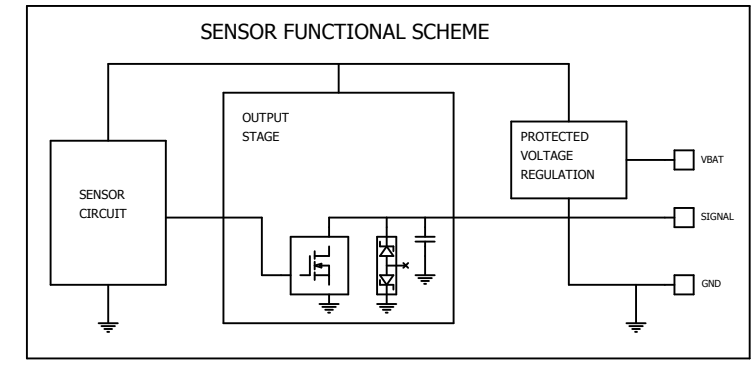
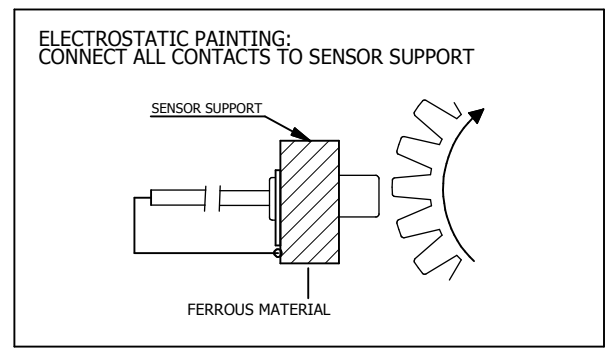
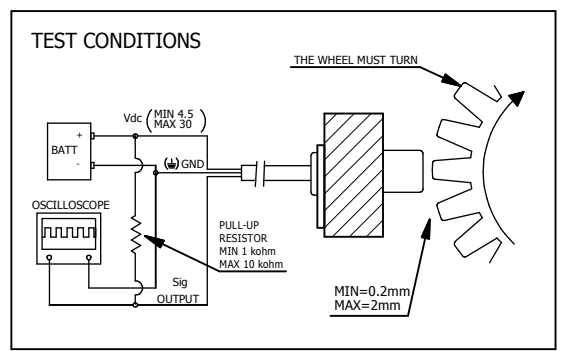

NOTES: ELEN SRL RESERVES THE RIGHT TO MAKE MODIFICATIONS/ENHANCEMENTS TO ITS PRODUCTS, GIVING NOTICE TO THE CUSTOMERS.
ELEN SRL ASSUMES NO LIABILITY FOR NON PROPER USE OF ITS PRODUCTS AND FOR APPLICATIONS OUTSIDE OF THE INDICATED SPECIFICATIONS.