

Sensori di temperatura NTC con allarme

NTC temperature sensors with alarm signal



- Combinano un termistore NTC ed un termostato bimetallico
 - Misurano la temperatura e forniscono un segnale di allarme su contatti separati
 - Resinati internamente e resistenti fino 160°
 - Configurabili valori di scatto del bimetallo, curva NTC, interconnessione
 - Immuni ai disturbi elettrici ed elettromagnetici
 - Impiegabili nei settori automotive, agricolo, movimento terra, industriale, ferroviario, nautico
- They combine a NTC thermistor and a bimetal thermostat
 - They measure the temperature and provide an alarm signal on different contacts
 - Internally resinated and resistant until 160°C
 - Customizable bimetal temperature threshold, NTC curve and connections
 - Immune to electric and electromagnetic disturbances
 - Applicable in automotive, agricultural, earth moving, industrial, railway and nautical fields

DIMENSIONS

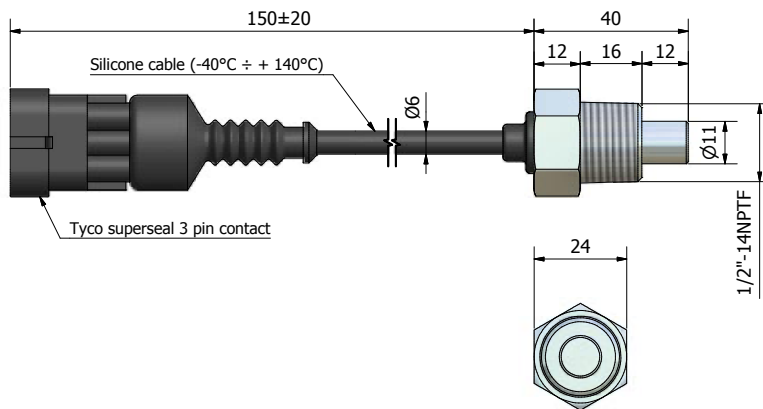
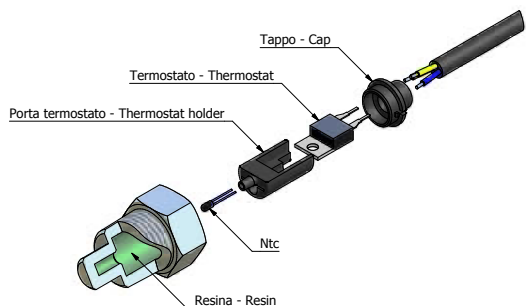

APPLICATIONS

Resistance-temperature diagram

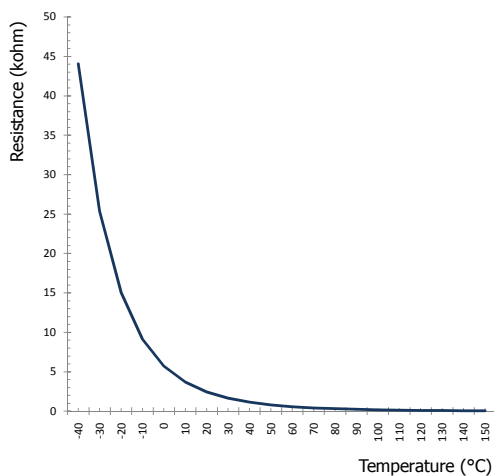

TEMPERATURE (°C)	RESISTANCE (kohm)	ΔRESIST. (+/- %)	ΔTEMP. (+/- °C)
-40	44,060	4,4	0,8
-30	25,392	3,8	0,7
-20	15,034	3,2	0,6
-10	9,137	2,6	0,5
0	5,733	2,1	0,5
10	3,688	1,7	0,4
20	2,431	1,3	0,3
30	1,660	1,2	0,3
40	1,142	1,6	0,5
50	0,8109	2	0,6
60	0,579	2,3	0,7
70	0,4237	2,6	0,9
80	0,3136	2,9	1
90	0,2364	3,2	1,2
100	0,1815	3,4	1,3
110	0,1402	3,7	1,5
120	0,1096	3,9	1,6
130	0,08683	4,2	1,8
140	0,06923	4,4	2
150	0,5582	4,6	2,2

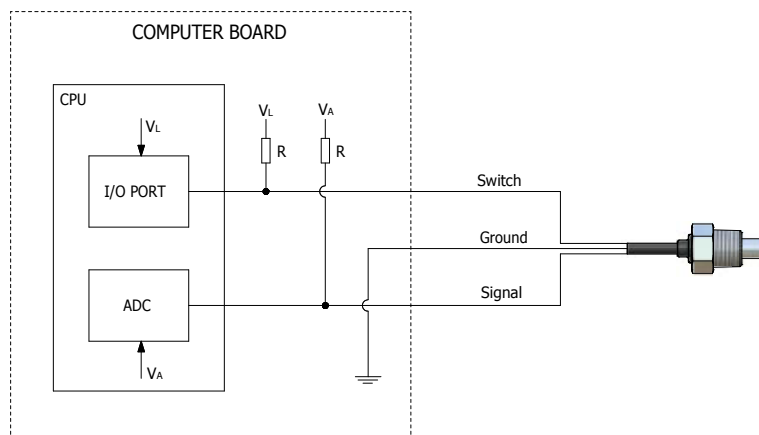

SPECIFICATIONS

CHARACTERISTICS	VALUE
Technology:	integrated chip bimetal
Resistance value 25°C:	2 kohm
Resistance tolerance at 100°C:	± 1%
Max switchable load :	1A (non inductive)
Close on rise temperature:	115 °C ± 5 °C
Opening temperature:	109 °C ± 80 °C
Contact:	N.O.
Housing material:	AVP lathed
Treatment:	galvanized surface
Tightening torque:	30 Nm
Operating temperature:	- 30 °C ÷ + 150 °C
Power supply:	6 ÷ 24 Vdc
Vibrations resistance:	1 mm/100Hz (~8g); ref. EN 60068-2-6
Degree of protection:	IP67; ref IEC 60529
Life cycle:	0k; ref. EN 60068-2-14b
Current sink:	max power dissipate 60mW @ 25°C