

Sensori di prossimità per cilindri oleodinamici inox (1)

Proximity switch sensors for st. steel hydraulic cylinders (1)



- Sensori di prossimità/fine corsa non a contatto
- Rilevano presenza/assenza di campo magnetico all'interno di cilindri inox (diamagnetici)
- Distanza di rilevamento > 10 mm dalla plastoferrite collocata sul pistone traslante
- Impiegabili su assali con cilindri sterzanti per l'individuazione dell'allineamento delle ruote all'asse del veicolo (steering sensor)
- Proximity/limit contactless sensors
- They detect the presence/absence of magnetic field in inox cylinders (diamagnetic)
- Detection distance > 10mm from the plastic ferrite fixed on the shifting piston
- Suitable for the application on steering cylinders for the detection of the wheels alignment on the axis of the vehicle (steering sensor)

DIMENSIONS

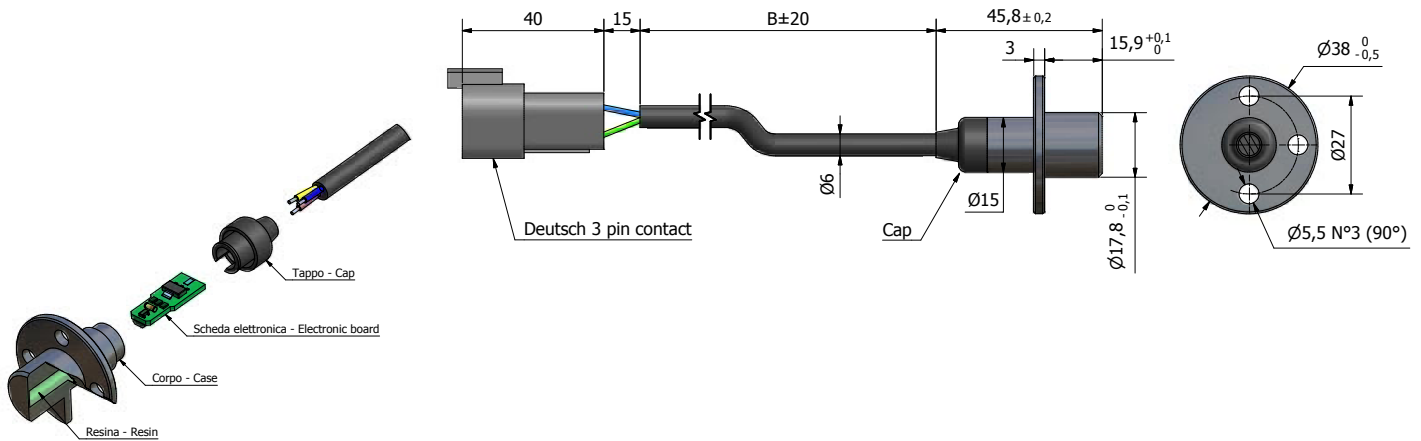

APPLICATIONS

Output signal

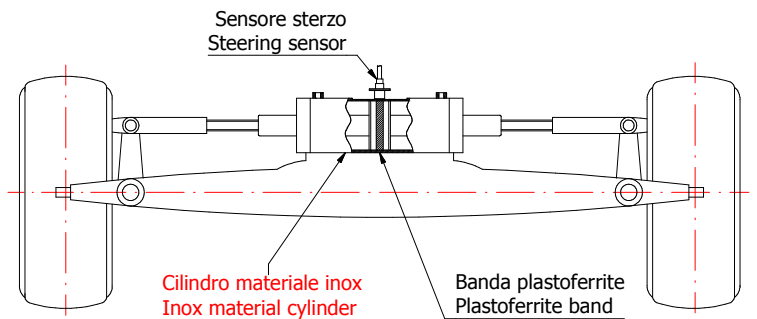
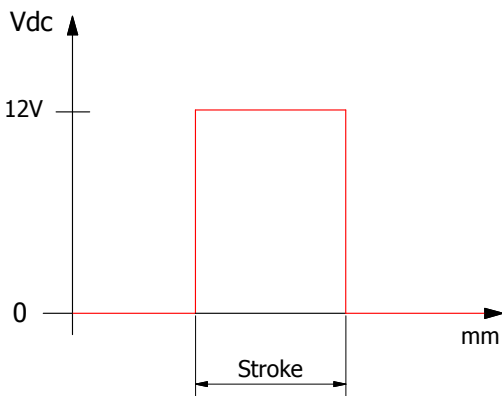

Connection diagrams

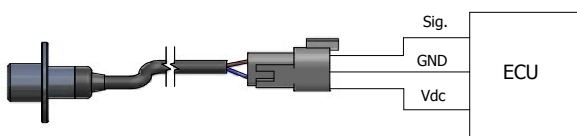

SPECIFICATIONS

CHARACTERISTICS	VALUE
Principle of operation:	Magnetostrictive
Power supply:	8 ÷ 30 Vdc
Absorbed supply:	80 mA @ 18 ÷ 80 °C
Output current:	max 700 mA
Output signal:	PNP
Min excitation magnetic field:	20 Gauss a 20°C; not operating under 16 Gauss
Housing material:	nylon
Operating temperature:	- 30 °C ÷ + 120 °C
Vibrations resistance:	1 mm/100Hz (~8g); ref. EN 60068-2-6
Degree of protection:	IP67; ref. IEC 60529
Reverse polarity protection:	in the sensor operating range every voltage
Overload protection:	840 mA per 5' a 20 °C
Direct drive:	lamps for max 700 mA